



# Weight Angel <sup>TM</sup>

MOBILE WEIGHT ANCHOR

Specialist and Unique Solutions to Height Safety Issues.  
We are here when nothing else works.



## Who is Bettersafe International?

We are specialists in working at height. Nothing else. No dilution, no separation, no compromise.

With over 40 years of experience within our walls we offer our partners high quality, industry leading fall protection equipment and unique solutions. Couple this with extensive training courses, exceptional quotation and technical support, and a very rapid response to required solutions, you have a winning formula to partner with.

## What does Bettersafe International do?

Fall protection. It's what we do at Bettersafe International. It's how we do it that is different.

Unlike the majority of suppliers our single focus is ensuring that our clients, you, get the product you need when you need it. This is done through large stocks and an open ear. We are relaxed and responsive, we always answer our phones and we are always willing to assist in whatever means we can.

For far too long product developers have been listening to the market through the ears of manufacturers. The voices of the users, the installers, the safety managers and building owners seem to have been lost in the wind.

Bettersafe International are doing things differently. We are listening.

We work alongside development partners to ensure that the products we deliver you are already field tested and designed for the market into which they are being placed. We offer a product developed for the market into which is to be used, and we price it to win. Simple as that.

## What are we looking for in partners?

We don't want "just another client". We are always on the look out for those people and companies in the industry who are of a like mind and disillusioned with their current supplier. People who are looking for something a little different. People like you.

If you are reading this then you are at least a little interested in something new, something different. You are already looking with at least one eye at what is happening and possibly looking to join a network of companies who want to change the face of fall protection for the better.

## Where have we been?

We have worked alongside some of the leading companies in the construction industry, with installations of our products being in some of the most prestigious of locations, such as football stadiums, airports and Government buildings across the globe.

We have key installations in Germany, Netherlands, Belgium, France, United Kingdom, Spain, Australia, United States, Canada, Norway, Sweden, Denmark, Eire, Italy.



Safety should be the priority of anyone working at height, but sometimes you need a smaller problem rectifying without wanting to put an extensive and time-consuming set of safety measures in place.

For those moments, we've created the freestanding Weight Angel post system, a fall protection solution that's simple to set up and deploy.

Weight Angel is a weight anchor designed to minimise the distance and consequences of a fall when a worker is attached to it. It is designed to be used on surfaces up to a 5 degree pitch and is simple and straightforward to use, allowing you to get the job done both quickly and safely.

A simple, straightforward safety solution without any risk of endangerment, the Freestanding Weight Angel post system is the perfect solution to a range of tasks where safety is paramount

The Freestanding Weight Angel post system consists of a set of non-penetrative weights assembled into a single, round unit. Working in conjunction with a shock absorbing post, Weight Angel creates a powerful friction anchor that is more than capable of withstanding a fall.

The unit has also been specifically designed to reduce trip hazards and to occupy as small a space as possible on the roof: it's no more than 1200mm wide. Suitable for the full range of flat roofs (up to a maximum of 5° pitch), the Weight Angel system has been tested on a range of substrates including concrete, ashfelt and single ply membrane. Its quality has also been assured by external means, and it is fully tested by SATRA to BS EN795:2012 Type E.

With its competitive pricing and high recycled material content, it's safe and kind to the environment.





## Key Features

- Small but substantial product: a minimal trip hazard
- Rapid Installation possible with a single user.
- Small number of components
- Easy to assemble and store when not in use
- Non-penetrative: ideal for older buildings
- Single user Fall Arrest
- Two user Fall Restraint
- Weights have built in handles to protect users hands during installation
- Usable on flat roofs no steeper than a 5° pitch
- Tested on a wide range of roofs and materials
- Competitively priced. Without any compromise in quality
- Environmentally friendly due to recycled and recyclable materials.
- Can be used with the Roof Angel system to create a restraint access line with fall arrest options.

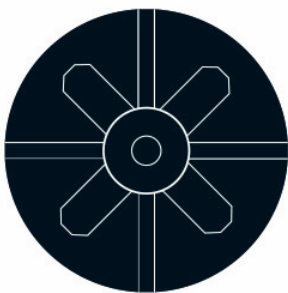

Ø 1200mm



manufactured using  
recycled material



maximum roof pitch



two-person system

*Restraint only.*



# Weight Angel & Roof Angel

MOVABLE WEIGHT ANCHOR

HORIZONTAL LIFELINE SYSTEM

## Restraint Access Line

Weight Angel and Roof Angel can be used in conjunction with each other to create a non-penetrative horizontal lifeline.

The system can be used for up to two users in restraint.

To be classified as restraint, the position of the anchorage and cable systems, used with the correct length of the lanyard must ensure it is not possible to approach within 500mm of a roof edge or other opening where a fall risk is present.

This system is a restraint access line, but with each Weight Angel installed with a Thro Plate and D-Ring then each Weight Angel can be used as an individual fall arrest anchorage point.

Used with the RA-2012 Thro Plate and RA-2006 D Ring each anchor can be used as a fall arrest anchor when connected to the D Ring and not the cable.

This allows the user to access in restraint the area where work is to be carried out and only then convert to fall arrest.

It is intended for use on flat roofs or where it is preferable that penetration of the roof surface be avoided.



# KEY SPECIFICATIONS

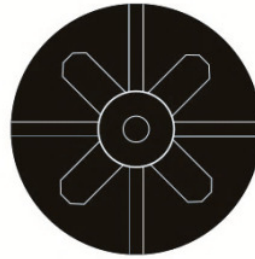
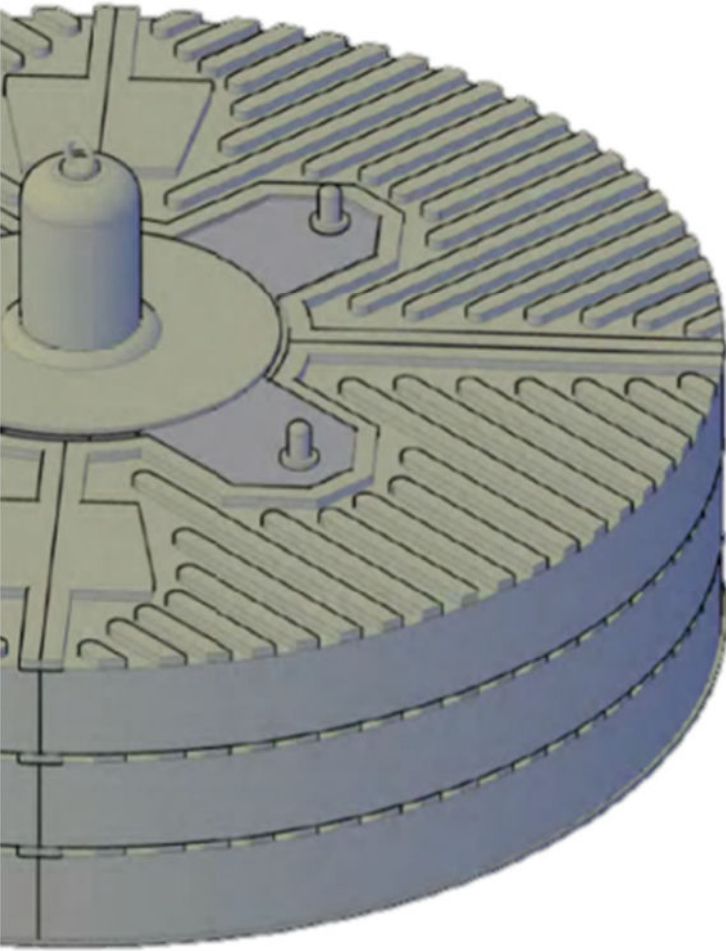

Ø 1200mm



Ø 1200mm

Weight	300 kg
Individual Weights	24 kg
Qty Weights	12 units
Weight of posts /supports	12 kg
Width	1200 mm
Height	465 mm
Made from Recycled Materials	

## MATERIALS

Post	Polyurethane
Eye Ring	SS 316
Cover	Aluminium
Bolts	SS 316

## INSTALLATION LIMITATIONS

The Weight Angel Safety System is designed with the following limitations:

- Fall Arrest for one (1) users
- Fall Restraint for two (2) users
- Maximum roof pitch of five (5) degrees

### Roofing Materials

- Single Ply Membrane
- Single Ply Bitumen Membrane with stone covering
- Single Ply Membrane Bitumen
- Concrete Deck

### Weather

- Wet surfaces are tested
- Dry surfaces are tested

Conforms to EN795:2012



## MATTING SPECIFICATIONS

Elastomer	Natural
Colour	Black
Quality	Commercial
Grade	N02
Hardness	70° shore a
S.G.	1.55g/cm <sup>3</sup>
Tensile MPA	4
Elongation	300%
Tear strength	12 kg/cm
Compression set	43%
Abrasion resistance	48/0 mm <sup>3</sup>
Operating temperature	-20° / +70° c

# Restraint Access Line

## Components

- Weight Angel
- Roof Angel

## Materials

- Stainless Steel / Rubber / Galvanised Steel

## Specifications

- Maximum Span 10m
- Maximum Users 2

## Conformity

- CE Approval EN 795:2012 Type E (Weight Angel)
- EN 795:2012 Type C (Roof Angel)
  - Roof Angel to be used as restraint ONLY
  - User must not be allowed to get within 0.5m of a fall risk
- BS 7883
- BS 8437:2005

## Benefits

Does not require the roof surface to be penetrated.  
The Weight Angel can be used on any of the following roof surfaces in WET or DRY conditions:

- Single Ply Membrane
- Asphalt
- Concrete
- Stone Chippings (Brushed)
- Mineral Felt

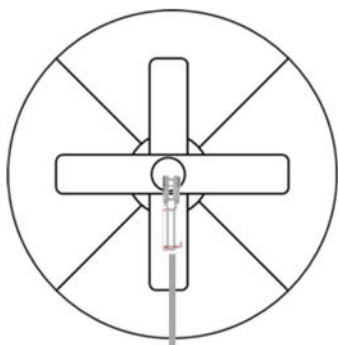

- End Anchor
- Weight Angel
  - RA-2006 D-Ring
  - RA-2002 Fork End

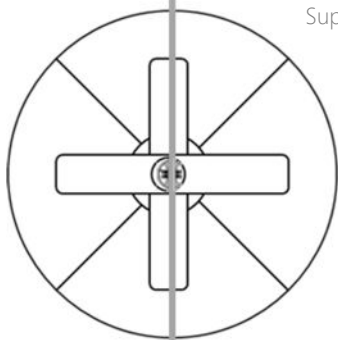

- Intermediate Anchor
- Weight Angel
  - RA-2003 Intermediate Support

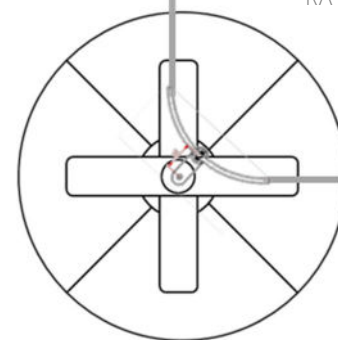

- Corner Anchor
- Weight Angel
  - RA-2008 Corner Support

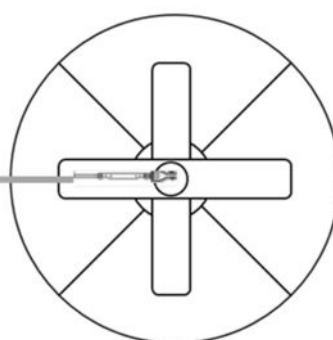

- End Anchor
- Weight Angel
  - RA-2006 D-Ring
  - RA-2001 Tensioner



UK  
Riverside  
Mountbatten Way  
Congleton  
Cheshire  
CW12 1DY  
United Kingdom

t | + 44 (0) 1260 217 437

NETHERLANDS  
Azewijnseweg 12 SF  
4214 KC Vuren  
The Netherlands

t | + 31(0) 183 820 280

[info@bettersafeinternational.com](mailto:info@bettersafeinternational.com)  
[www.bettersafeinternational.com](http://www.bettersafeinternational.com)

