

+ FA 60 105 00

A	15,5 cm
B	17 cm
C	16 cm
X	13,5 cm
Y	28 cm

FA 60 003 30
FA 60 003 30S

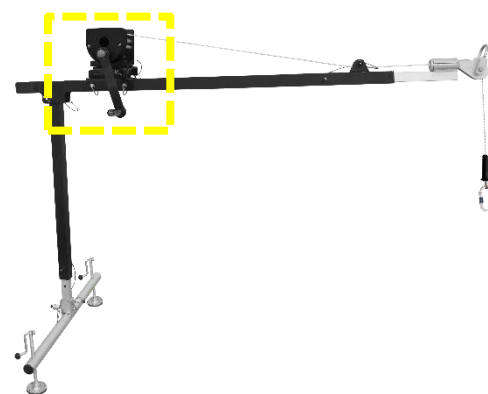

+ FA 60 106 00





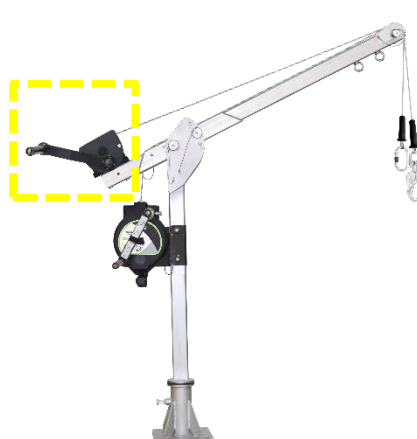

+ FA 60 001 00 / FA 60 002 00



+ FA 60 022 00



HS CODE
84251900
CARTON SIZE / PCS.
40 x 30 x 20 cm / 1
Certificate of Test n°SPC0256516/1716 Issue 2 Ext. 1
Satra Technology Centre, N°0321 Wyndham Way, Telford Way, Kettering Northamptonshire, NN16 8SD, United Kingdom

REF.	FA 60 003 30 FA 60 003 30S	
LG.	30 m	
CE	EN 1496:2017 Class A	
	x1	
	135 KG	
MAT. 	STEEL Ø 4.8 mm INOX Ø 4.5 mm	
	STEEL INOX	
	(1) EN 13157 (1) Machinery Directive: 250 KG (1) ATEX Directive:  II 2 G Exh IIC T6 Gb	
+	(2) Compatible FA 60 001 00, FA 60 002 00 (2) Compatible FA 60 101 00, FA 60 102 00, in combination with FA 60 101 02 (2) Compatible FA 60 022 00, in combination with FA 60 022 06 (2) Compatible FA 60 105 00, FA 60 106 00, in combination with FA 60 105 02	
	8.75 KG	8.97 KG



Nombre d'utilisateurs
Number of users
Cantidad de usuarios
Quantità di utilizzatori
Anzahl der Benutzer



Charge maxi admissible
Max. allowed load
Carga máxima admisible
Carico massimale ammissibile
Zulässige Höchstlast



MAT. **Matière câble**
Material wire rope
Material cable
Material dei cavo
Material Seil

+



(1)
Point fort
Key feature
Ventaja principal
Punti forti
Produktvorteil

(2)
À utiliser avec
To be used with
Para usar con
Ad essere utilizzato con
Verwendet werden soll mit

Matière connecteur
Material of connector
Material conector
Materiale connettore
Material Verbindungselement